

# Indexable Notching Head

Outer diameter: 9" to 14"

Cut width: 2" to 12"

Inner diameter: 1.5" to 3"

Radius: 1/2" corners (1" diameter)

Indexable carbide inserts (reversible)

Keyway: 1/4", 3/8", 1/2"

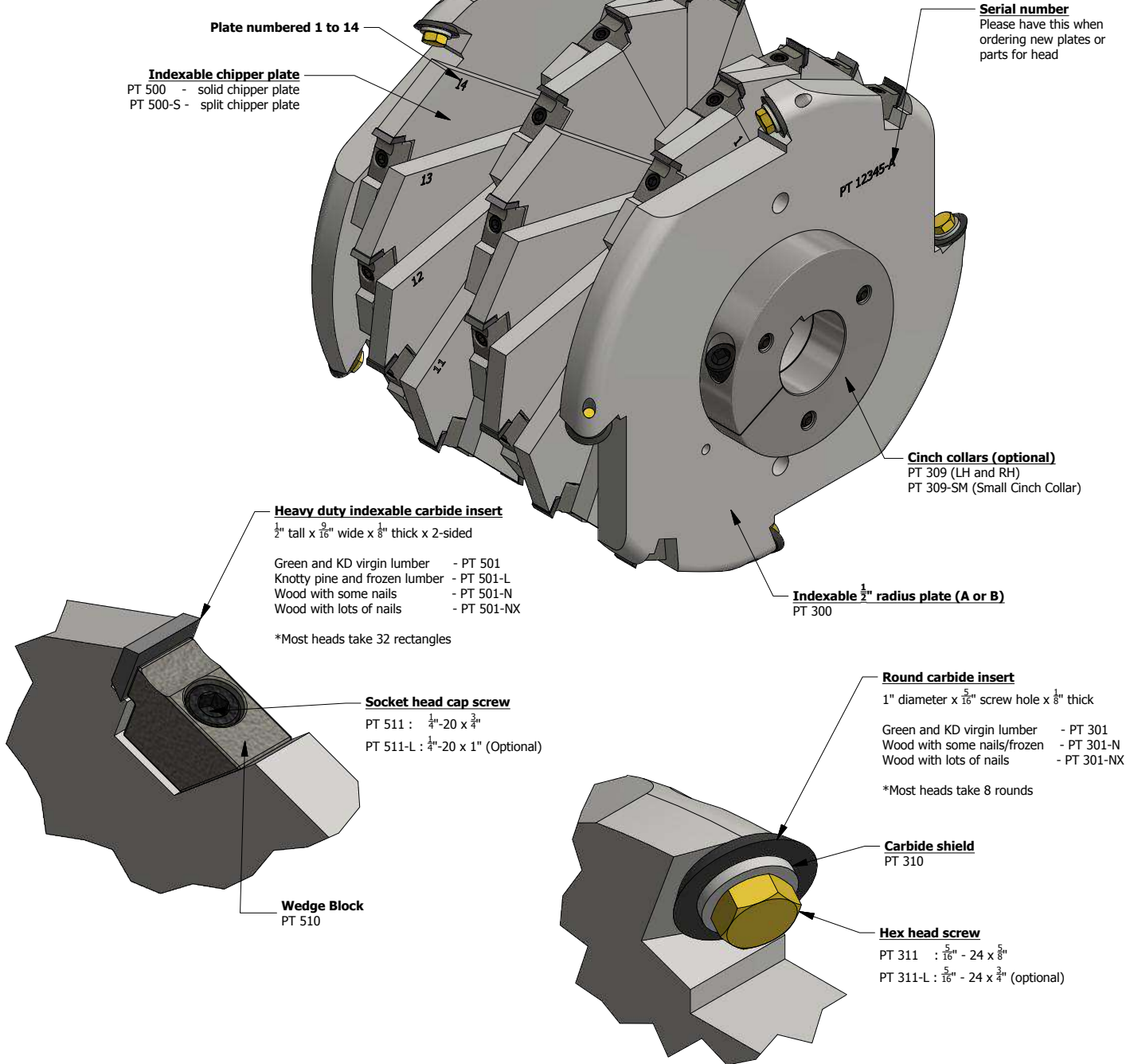

Plate numbered 1 to 14

**Indexable chipper plate**  
PT 500 - solid chipper plate  
PT 500-S - split chipper plate

**Serial number**  
Please have this when ordering new plates or parts for head

**Cinch collars (optional)**  
PT 309 (LH and RH)  
PT 309-SM (Small Cinch Collar)

**Heavy duty indexable carbide insert**  
1/2" tall x 9/16" wide x 8" thick x 2-sided

Green and KD virgin lumber - PT 501  
Knotty pine and frozen lumber - PT 501-L  
Wood with some nails - PT 501-N  
Wood with lots of nails - PT 501-NX

\*Most heads take 32 rectangles

**Indexable 1/2" radius plate (A or B)**  
PT 300

**Socket head cap screw**

PT 511 : 1/4"-20 x 3/4"  
PT 511-L : 1/4"-20 x 1" (Optional)

**Wedge Block**  
PT 510

**Round carbide insert**

1" diameter x 5/16" screw hole x 8" thick

Green and KD virgin lumber - PT 301  
Wood with some nails/frozen - PT 301-N  
Wood with lots of nails - PT 301-NX

\*Most heads take 8 rounds

**Carbide shield**  
PT 310

**Hex head screw**

PT 311 : 5/16" - 24 x 5/8"  
PT 311-L : 5/16" - 24 x 3/4" (optional)



**PROFILE TECHNOLOGY INC.**

Custom Engineered Tooling and Machinery

300 Seebold Spur  
Fenton, MO 63026  
www.profiletech.com

(800) 369-4242 toll free  
(314) 965-9111 main  
(314) 966-5550 fax  
info@profiletech.com

